

## 1 INSTALLATION

Mount in a cabinet, engine enclosure, or sealed metal box.



Vertical orientation allows for the draining of fluids in moist environments.



Avoid Extreme Heat

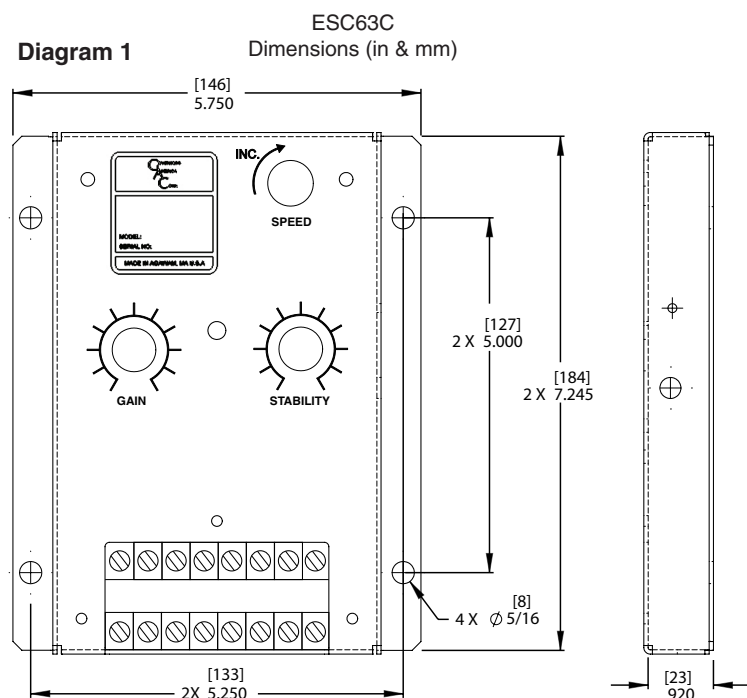

**WARNING** An overspeed shut down device, independent of the governor system, should be provided to prevent loss of engine control, which may cause personal injury or equipment damage.

## 2 WIRING

Electrical connections are illustrated in Diagram 1. Actuator and battery connections to Terminals B, C, D and H should be #16 AWG. (1.3 mm sq.) or larger and should be twisted for their entire length. The battery positive (+) input terminal should be fused as illustrated.

Diagram 2

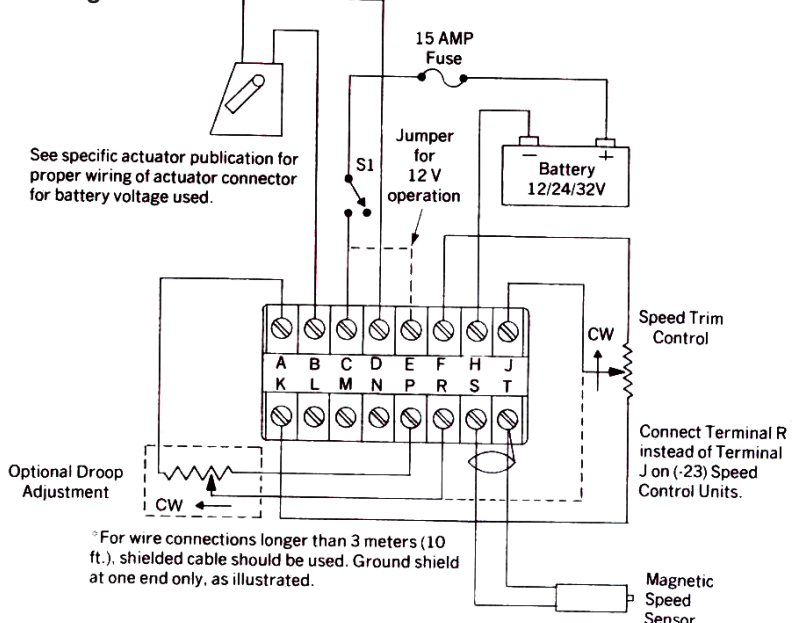

## Connecting the Magnetic Speed Sensor:

Magnetic speed sensor connections to Terminals S and T must be twisted or shielded for their entire length. The speed sensor cable shield should only be connected to Terminal T. The cable shield should be insulated to insure no part of the shield comes in contact with engine ground, otherwise stray signals may be introduced to the speed control.

## 3 ADJUSTMENTS

### NOTE Before Starting the Engine:

1. Check to insure that the GAIN, STABILITY, and external SPEED TRIM are set to their mid-positions.
2. Check the fail-safe features of the controller and part of the actuator wiring by applying D.C. battery current to the governor system by closing S1, shown in Diagram 2. The actuator should momentarily move, but must return to minimum fuel position.

### Start the Engine

The speed control unit is factory set at approximately engine idle speed. (1000 Hz. speed sensor signal)  
Crank the engine with D.C. power applied to the governor system. The actuator will energize to the maximum fuel position until the engine starts. The governor system should control the engine at a low idle speed. If the engine is unstable after starting, turn the GAIN and STABILITY adjustments counterclockwise until the engine is stable.

### Governor Speed Setting

The governed speed set point is increased by clockwise rotation of the SPEED adjustment pot. Remote speed adjustment can be obtained with an optional Speed Trim Control. (See Diagram 2)

### Governor Performance

Once the engine is at operating speed and at no load, the following governor performance adjustment can be made.

1. Rotate the GAIN adjustment clockwise until instability develops. Gradually move the adjustment counterclockwise until stability returns. Move the adjustment one division further counterclockwise to insure stable performance.
2. Rotate the STABILITY adjustment clockwise until instability develops. Gradually move the adjustment counterclockwise until stability returns. Move the adjustment one division further to insure stable performance.
3. GAIN and STABILITY adjustments may require minor changes after engine load is applied. Normally, adjustments made at no load achieve satisfactory performance. A strip chart recorder can be used to further optimize the adjustments.

If instability cannot be corrected or further performance improvements are required, refer below to the Section 4 TROUBLESHOOTING.

### Speed Droop Operation

Adjustable droop can be obtained by connecting a 50K potentiometer to Terminals A, P, and R as illustrated in Diagram 2. The range of droop is dependent on the change of actuator current and the frequency of the speed sensor signal.

With the engine at rated speed and full load, turn the droop control 1/2 turn clockwise. Re-adjust the engine speed to the rated speed setting. Remove the engine load and note the engine speed the percentage of droop obtained. To increase the percent of droop, rotate the droop control clockwise. Decreases in the percent of droop will require counterclockwise rotation of the droop control.

Droop is typically used for paralleling of engine driven generators. Usually 3% droop is adequate for engine paralleling or for non-generator set applications.

### Idle Speed Setting (ESC63C-23 ONLY)

Place the cover mounted selector switch in the "IDLE" position. Idle speed setpoint is increased by clockwise rotation of the IDLE adjustment control.

### Accessory Input

The accessory Terminal R (J on ESC63C-23) accepts input signals from load sharing units, auto synchronizers, and other governor system accessories. GAC accessories are directly connected to this terminal. It is recommended that this connection from accessories be shielded, as it is a sensitive input terminal.

### Accessory Supply

The +10 Volt supply, Terminal K, is used to provide power to load sharing units and other GAC governor system accessories. Ground reference is Terminal F.

## 4 TROUBLESHOOTING

### System Inoperative

If the governing system does not function, the fault may be determined by performing the voltage tests described in Steps 1 & 2; (+) and (-) refer to meter polarity. Should normal values be indicated, the fault may be with the actuator or the wiring to the actuator. See specific actuator publication for testing details.

| STEP | TERMINALS   | NORMAL READING                             | PROBABLE CAUSE OF ABNORMAL READING   |
|------|-------------|--|--|
| 1    | S(+) & T(-) | 1.0 VAC RMS min. while cranking)           | 1. Gap between speed sensor and gear teeth too great. Check gap.<br>2. Improper or defective wiring to the speed sensor. Resistance should be between 30 to 1200 ohms.<br>3. Defective speed sensor. |
| 2    | C(+) & F(-) | Battery Supply Voltage (12, 24, or 32 VDC) | 1. DC battery power not connected. Check for blown fuse<br>2. Low battery voltage<br>3. Wiring error   |
| 3    | J(+) & H(-) | 10 VDC, Internal Supply                    | 1. Short on Terminal K or defective accessory<br>2. Defective speed control unit   |
| 4    | B(+) & H(-) | 2.0 VDC while cranking                     | 1. SPEED adjustment set too low.<br>2. Wiring error to actuator.<br>3. Defective speed control unit.<br>4. Defective actuator  |

### Unsatisfactory Performance

| SYMPTOM                                     | NORMAL READING  | PROBABLE CAUSE OF ABNORMAL READING   |
|---|---|--|
| Engine Overspeeds                           | 1. Do Not Crank. Apply DC power to the governor system.   | 1. Actuator goes to full fuel. Then disconnect the speed sensor wires (Terminals S & T). If actuator still at full fuel speed control unit defective. If actuator at minimum fuel position erroneous speed signal. Check speed sensor cable.   |
|   | 2. Manually hold the engine at the desired running speed. Measure the DC voltage between the B and F on the speed control unit. | 1. If the voltage reading is 1.5 to 2.5 VDC:<br>a. SPEED adjustment set above desired speed<br>b. Defective speed control unit<br>2. If voltage reading is battery voltage check for:<br>a. actuator binding<br>b. linkage binding<br>3. If the voltage reading < 1.5 VDC:<br>a. defective speed control unit. |
| Actuator does not energize fully            | 1. Measure the battery voltage while cranking. It must not be less than 8 VDC.  | 1. Replace the battery if weak or undersized.  |
|   | 2. Momentarily connect B to F. The actuator should move to the full fuel position.  | 1. Actuator or battery wiring in error<br>2. Actuator or linkage binding<br>3. Defective actuator  |
| Engine remains below desired governed speed | 1. Measure the actuator output, B and D, while running under governor control.  | 1. If voltage measurement is with 2 volts or more of the battery supply voltage level, then fuel control restricted from reaching full fuel position. Possibly due to mechanical governor, carburetor spring, or linkage interference.<br>2. If not, increase speed setting.                                   |

## 5 SPECIFICATIONS

| PERFORMANCE  |   |
|--|---|
| Isochronous Operating / Steady State Stability                     | ± 0.25% or better                                       |
| Speed Range  | 300 - 10K Hz continuous                                 |
| Droop Range  | 0 - 5% regulation                                       |
| Speed Drift with Temperature                                       | < ±1%   |
| Speed Trim Range   | ± 200 Hz  |
| Terminal Sensitivity<br>R<br>J (without jumper)<br>J (with jumper) | 104 Hz/Volt<br>40 Hz/Volt<br>1100 Hz/Volt               |
| POWER INPUT  |   |
| Supply   | 11- 40 VDC<br>(Transient and reverse voltage protected) |
| Polarity   | Negative ground, case isolated                          |
| Power Consumption  | 60 mA continuous plus actuator current                  |
| Maximum Actuator Current at 25°C (77°F)                            | 20 Amps   |
| Speed Sensor Signal  | 0.25 to 120 VRMS  |
| Speed Sensor Signal - Impedance                                    | 5.0K ohms   |
| ENVIRONMENTAL  |   |
| Ambient Temperature  | -65° to 180°F (-55 to 82°C)                             |
| Relative Humidity  | Up to 95%   |
| All Surface Finishes   | Fungus Proof and Corrosion Resistant                    |
| RoHS Regulation  | Compliant   |
| RELIABILITY  |   |
| Vibration  | 5G @ 20 - 500 Hz  |
| Testing  | 100% Functionally Tested                                |
| PHYSICAL   |   |
| Dimension  | See SECTION 1 Diagram 1                                 |
| Weight   | 2.0 lbs (0.9 kg)  |
| Mounting   | Any position, Vertical Preferred                        |